



Part Number:

DK-LC-18-OD-4CH-A2-24V-PS9.2A-XX

Product Naming Convention:

DK-LC-18-OD-4CH-A2-24V-PS9.2A-XX

① - ② - ③ - ④ - ⑤ - ⑥ - ⑦ - ⑧ - ⑨

1. Demo Kit
2. Light Controller
3. Series 18
4. Overdrive
5. 4 Channels
6. Lighting Output Current 2.0A
7. Power Adapter Voltage : 24V
8. Power Adapter Current: 9.8A
9. Power Cord Type: UK/US/EU

Specifications:

Type	Digital Controller
Series	LC-18 Series
Dimension	120 x 94.1 x 67 mm
Communication Type	RS232, TCP/IP
Controller Supply Voltage	24VDC
Output Current	2A / Channel
Lighting (Input Voltage)	24V
Lighting (Output Voltage)	Based on lighting input voltage
Digital Input	4
Digital Output	4
No. of channel	4 Channels
Mode	Strobe
Strobe Width	0 - 100ms (0.01ms / step)
Trigger Delay	≤ 25μs

Box Dimension:

L 350 x W 145 x H 220

Application

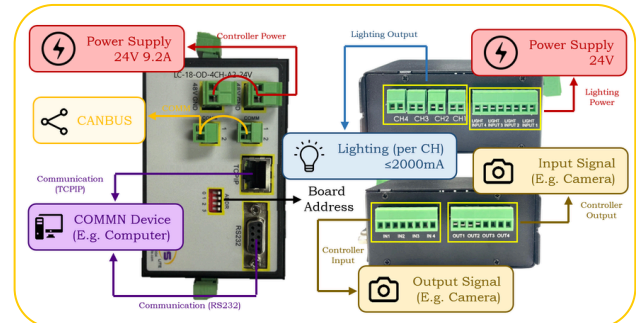

Features

- Intensity control for LED lighting in machine vision applications
- 4 channels with individual settings
- 1 mode of operation for diverse application support

Advantages

- Programmability
- Able to control multiple lighting
- Software control
- Able to overdrive for 12V lighting

Benefits

- Compact size
- Fast respond in strobing
- Easy to install