

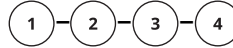

Part Number:
LC-18-1CH-X10

Product Naming Convention:

LC-18-1CH-X10



1. Light Controller
2. Series 18
3. 1 Channel
4. Lighting Output Current 10.0A (without Master Board)

Specifications:

Type	Digital Controller
Series	LC-18 Series
Dimension	120 x 93.5 x 83.6 mm
Communication Type	To be connected with LC-18-M
Controller Supply Voltage	12V ~ 24VDC
Output Current	10A / Channel
Lighting (Input Voltage)	5V, 12V, 24V and 48V
Lighting (Output Voltage)	Based on lighting input voltage
Digital Input	1
Digital Output	1
No. of channel	1 Channel
Mode	Constant, Strobe & Trigger
Strobe Timing	0 - 99.99ms (0.01ms / step)
Trigger Delay	≤ 25μs

Application

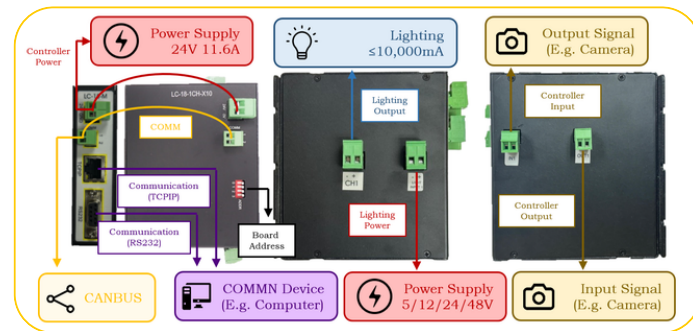

Features

- Intensity control for LED lighting in machine vision applications
- Single channel with high current output
- 3 modes of operation for diverse application support
- Need connect with LC-18-M

Advantages

- Programmability
- Able to control lighting up to 10A current
- Software control
- Able to cascade via control board address

Benefits

- Compact size
- Fast respond in strobing
- Easy to install